



ICC-ES Evaluation Report ESR-3750

Reissued June 2022

This report is subject to renewal June 2024.

DIVISION: 31 00 00—EARTHWORK
Section: 31 63 00—Bored Piles

REPORT HOLDER:

IDEAL MANUFACTURING, INC.

EVALUATION SUBJECT:

IDEAL HELICAL FOUNDATION SYSTEMS

1.0 EVALUATION SCOPE

Compliance with the following codes:

- 2021, 2018, 2015, 2012, 2009 and 2006 *International Building Code*® (IBC)

For evaluation for compliance with codes adopted by the Los Angeles Department of Building and Safety (LADBS), see [ESR-3750](#) LABC Supplement.

Properties evaluated:

- Structural
- Geotechnical

2.0 USES

The Ideal Helical Foundation Systems are used either to underpin foundations of existing structures or to form deep foundations for new structures and are designed to transfer compression, tension, and lateral loads from the supported structure to suitable soil bearing strata. Underpinning of existing foundations is generally achieved by attaching the helical piles to the repair brackets (Type A side-load brackets), which support compression loads. Deep foundations for new construction are generally obtained by attaching the helical piles to new construction brackets (Type B direct-load brackets) that are embedded in concrete pile caps, footings, or grade beams, which support compression, tension and lateral loads.

3.0 DESCRIPTION

3.1 GENERAL:

The Ideal Helical Foundation Systems consist of a helical pile and a bracket that allows for attachment to support structures. Each helical pile, consisting of a lead shaft

section and one or more extension shaft sections, as needed to reach depth, is screwed into the ground to a desired depth and suitable soil bearing strata by applying torsion and crowd. The bracket is then installed to connect the helical pile to the concrete foundation of the supported structure.

3.2 System Components:

The Ideal Helical Foundation Systems include either a 1½-inch (38 mm) solid round-cornered square (RCS) steel bar, 27/8-inch-outside-diameter (73 mm) round steel tubing, or 3½-inch-outside-diameter (89 mm) round steel tubing lead shaft, extension shaft(s), and either a repair bracket or a new construction bracket for attachment to concrete foundations. A lead shaft section is connected to extension shaft(s) by couplings, as described in Section 3.2.3. The helical pile is connected to a foundation bracket, as described in Section 3.2.4.

3.2.1 Helical Pile Lead Shafts, Extensions, and Flighted Extensions:

The Ideal Helical Foundation Systems helical pile lead shaft and extension shaft sections are available in three different shaft sizes: 27/8-inch-outside-diameter (73 mm) round steel tubing, 3½-inch-outside-diameter (89 mm) round steel tubing, and 1½-inch (38 mm) solid round-cornered square (RCS) steel bar. The helical pile lead shafts consist of one or more helical-shaped circular steel plates factory-welded to the steel shaft. The steel extensions may or may not include helical bearing plates, depending on the project specifications. The extension shaft sections are similar to the lead shaft sections, except that the extensions do not typically have helical plates. See Figures 3A, 3B, and 3C of this report. Whereas, flighted extension shaft sections are extension shaft sections with helical plates factory-welded to the steel shaft, similar to lead shaft sections. See Figures 5A, 5B, and 5C. The depth of the helical piles in soil is typically extended by adding one or more steel shaft extensions that are mechanically connected together by couplers to form one continuous steel pile.

The 27/8-inch-outside-diameter (73 mm) round steel tubing lead shaft sections and extension shaft sections are available in two wall thicknesses: a nominal wall thickness of 0.203 inch (5.15 mm) or 0.276 inch (7.01 mm). The 3½-inch-outside-diameter (89 mm) round steel tubing lead shaft sections and extension shaft

ICC-ES Evaluation Reports are not to be construed as representing aesthetics or any other attributes not specifically addressed, nor are they to be construed as an endorsement of the subject of the report or a recommendation for its use. There is no warranty by ICC Evaluation Service, LLC, express or implied, as to any finding or other matter in this report, or as to any product covered by the report.

sections are available in two wall thicknesses: a nominal wall thickness of 0.216 inch (5.48 mm) or 0.300 inch (7.62 mm). The 1¹/₂-inch (38.1 mm) round-cornered square (RCS) lead shaft sections and extension shaft sections are solid steel bars.

The helical lead shaft and extension shaft sections come in a range between 2.5-foot-long (0.76 m) to 20-foot-long (6.10 m). See Figures 3A, 3B, 3C, 4A, 4B, 4C, 5A, 5B, and 5C.

3.2.2 Helix Plates: The helical plates, which are factory-welded to the lead shafts and flighted extension shafts, allow advancement into the soil as the pile is rotated. Each circular, helical, steel bearing plate (helix) is split from the center to the outside edge with spiral edge geometry. Each helix is press-formed to a clockwise downward spiral with all radial sections normal to the shaft's central longitudinal axis $\pm 3^\circ$ and with a 3-inch nominal pitch. The pitch is the distance between the leading and trailing edges.

For 2⁷/₈-inch-outside-diameter (73 mm) and 3¹/₂-inch-outside-diameter (89 mm) round steel tubing shafts, the helix plates are 1/2-inch thick (12.7 mm) and have an outer diameter of 8, 10, 12 or 14 inches (203, 254, 305 or 356 mm). For 1¹/₂-inch (38 mm) RCS shafts, the helix plates are 3/8-inch-thick (9.52 mm) steel plates and have an outer diameter of 8, 10, 12 or 14 inches (203, 254, 305 or 356 mm).

The lead helix is located near the tip (bottom end) of the lead shaft section. For multiple helix installation, the helical bearing plates are spaced three times the diameter of the preceding helix plate apart, starting at the tip (bottom) of the lead shaft section. Typically, the smallest diameter helical bearing plate is placed near the tip (bottom) of the lead shaft section and the largest diameter helical bearing plate is placed near the top (trailing end) of the lead shaft section. When flighted extensions are utilized, the helix spacing between the last (or upper most) helix on the lead shaft and the first (or lower most) helix on the succeeding flighted extension shall be at least three times the helix diameter of the last (or upper most) helix on the lead shaft. For flighted extension shaft sections with multiple helix installation, the helical bearing plates are spaced apart three times the diameter of the lower preceding helix plate, starting from the bottom of the flighted extension shaft. See Figures 4A, 4B, 4C, 5A, 5B and 5C, and Tables 4A, 4B and 4C.

3.2.3 Extension Shaft Couplers: The helical pile lead shaft sections and extension shaft sections are connected together by couplers, so as to allow the multiple shaft sections to be connected during installation. Connection of the extension shaft section to the lead shaft or other extension shaft section is made by through-bolted connection, through the extension shaft coupler segment and the connected lead shaft or other extension shaft.

At one end of each 2⁷/₈-inch-outside-diameter (73 mm) and 3¹/₂-inch-outside-diameter (89 mm) extension shaft sections is a steel coupler that consists of a pipe sleeve, factory-welded to the end of the extension shaft, which allows the upper end to the lead shaft or the other end of extension shaft section to be snug-fitted into the welded coupler. The 2⁷/₈-inch-outside-diameter (73 mm) extension shaft coupler sleeve is a 3¹/₂-inch-outside-diameter (89 mm) round steel tubing, having a 0.254-inch (6.45 mm) nominal wall thickness. The 3¹/₂-inch-outside-diameter (89 mm) extension shaft coupler sleeve is a 4¹/₈-inch-outside-diameter (105 mm) round steel tubing, having a 0.255-inch (6.48 mm) nominal wall thickness. ¹³/₁₆-inch holes are factory drilled

at each end of the extension shaft section and at the upper end of the lead shaft section, so as to allow multiple shaft sections to be through-bolted together during the installation. For 2⁷/₈-inch-outside-diameter (73 mm) and 3¹/₂-inch-outside-diameter (89 mm) helical plies, each coupling connection includes two 3/4-inch-diameter (19 mm) standard hex-head structural bolts and two matching hex nuts complying with Section 3.3.6. See Figures 3A, 3B, 5A, and 5B.

At one end of each 1¹/₂-inch (38 mm) RCS extension shaft section, an upset socket is forged from the RCS steel bar, which allows the upper end of the lead shaft or the other end (the end without the upset socket) of an extension shaft section to be snug-fitted into the upset socket. ¹³/₁₆-inch holes are factory drilled at each end of the extension shaft section and at the upper end of the lead shaft section, so as to allow multiple shaft sections to be through-bolted together during the installation. The coupling connection includes one 3/4-inch-diameter (19 mm) standard hex-head structural bolt and one matching hex nut. See Figures 3C and 5C.

3.2.4 Foundation Attachments (Brackets): The Ideal 278CF and 312CF are Type A side-load brackets (repair brackets) used for transferring axial compressive loads from the existing foundations to the helical piles. The Ideal 278NC, 312NC, and SQ150NC are Type B direct-load brackets (new construction brackets) which are used in new construction to transfer axial compression, axial tension, or lateral loads from the foundations to the helical piles. The different brackets are described in Sections 3.2.4.1 and 3.2.4.2.

3.2.4.1 Repair Brackets (278CF and 312CF): Repair brackets are used to support existing concrete foundations by transferring axial compressive loads from the existing foundations to the helical pile.

The 278CF bracket is comprised of three components: seat, sleeve, and lifting T-bracket. The seat consists of 1/2-inch-thick (12 mm) top and bottom plates with 1/4-inch-thick (6 mm) vertical steel stiffener plates. The plates are factory welded together to form the seat. The seat is then factory welded to a round 3¹/₂-inch-outside-diameter (89 mm) steel tubing sleeve forming the bracket main body. A lifting T-bracket consists of factory welding together 1/2-inch-thick (12 mm) plates, 3/8-inch-thick (10 mm) plates, and round 2¹/₄-inch-outside-diameter (57 mm) steel tubing. The lifting T-bracket is connected to the bracket main body with two 7/8-inch-diameter steel threaded rods, four matching steel nuts, and matching steel washers. See Figure 1A of this report.

The 312CF bracket is comprised of three components: seat, sleeve, and lifting T-bracket. The seat consists of 1/2-inch-thick (12 mm) top and bottom plates with 3/8-inch-thick (10 mm) vertical steel stiffener plates. The plates are factory welded together to form the seat. The seat is then factory welded to a round 4¹/₈-inch-outside-diameter (105 mm) steel tubing sleeve forming the bracket main body. A lifting T-bracket consists of factory welding together 1/2-inch-thick (12 mm) plates and round 2⁷/₈-inch-outside-diameter (73 mm) steel tubing. The lifting T-bracket is connected to the bracket main body with two 7/8-inch-diameter steel threaded rods, four matching steel nuts, and matching steel washers. See Figures 1B of this report.

3.2.4.2 New Construction Brackets (278NC, 312NC, and SQ150NC): New construction brackets are used with the helical pile system in new construction where the steel bearing plate of the bracket is cast into new concrete grade beams, footings, or pile caps. The brackets can

transfer compression, tension, and lateral loads between the pile and the concrete foundation.

The 278NC bracket consists of an 8-by-8-by- $\frac{3}{4}$ -inch-thick (203 by 203 by 19 mm) bearing plate. The bearing plate is factory welded to a round $3\frac{1}{2}$ -inch-outside-diameter (89 mm) HSS sleeve with two factory-drilled $\frac{13}{16}$ -inch (24 mm) through-holes. The sleeve's wall thickness is 0.254 inches (6.45 mm). The bracket is attached to the shaft in the field with two $\frac{3}{4}$ -inch (19 mm) standard hex bolts with matching $\frac{3}{4}$ -inch (19 mm) standard hex nuts. See Figure 2A of this report.

The 312NC bracket consists of an 8-by-8-by- $\frac{3}{4}$ -inch-thick (203 by 203 by 19 mm) bearing plate. The bearing plate is factory welded to a round $4\frac{1}{8}$ -inch-outside-diameter (105 mm) HSS sleeve with two factory-drilled $\frac{13}{16}$ -inch (24 mm) through-holes. The sleeve's wall thickness is 0.255 inches (6.48 mm). The bracket is attached to the shaft in the field with two $\frac{3}{4}$ -inch (19 mm) standard hex bolts with matching $\frac{3}{4}$ -inch (19 mm) standard hex nuts. See Figure 2A of this report.

The SQ150NC bracket consists of an 8-by-8-by- $\frac{3}{4}$ -inch-thick (203 by 203 by 19 mm) bearing plate. The bearing plate is factory welded to a round $2\frac{3}{8}$ -inch-outside-diameter (60 mm) HSS sleeve with one factory-drilled $\frac{13}{16}$ -inch (24 mm) through-hole. The sleeve's wall thickness is 0.218 inches (5.54 mm). The bracket is attached to the shaft in the field with one $\frac{3}{4}$ -inch (19 mm) standard hex bolt with matching $\frac{3}{4}$ -inch (19 mm) standard hex nut. See Figure 2B of this report.

3.3 Material Specifications:

3.3.1 Helical Pile Lead Shafts and Extensions: The $2\frac{7}{8}$ -inch-outside-diameter (73 mm) and $3\frac{1}{2}$ -inch-outside-diameter (89 mm) lead shafts and extensions are carbon steel round tubes that conform to ASTM A500, Grade C, except they have a minimum yield strength of 80,000 psi (551 MPa) and a minimum tensile strength of 85,000 psi (586 MPa). The $1\frac{1}{2}$ -inch (38.1 mm) RCS lead shafts and extensions are solid round-cornered square (RCS) steel bar that conform to ASTM A29-15 and ASTM A576-90b, except they have a minimum yield strength of 90,000 psi (620 MPa) and a minimum tensile strength of 129,000 psi (889 MPa). The lead shafts and extensions can either be bare steel or hot-dipped galvanized in accordance with ASTM A123.

3.3.2 Helical Plates: The helical plates used in $2\frac{7}{8}$ -inch-outside-diameter (73 mm) and $3\frac{1}{2}$ -inch-outside-diameter (89 mm) lead shafts and extensions are carbon steel plates conform to ASTM A572, Grade 50, and having a minimum yield strength of 50,000 psi (344 MPa) and a minimum tensile strength of 65,000 psi (448 MPa). The helical plates used in $1\frac{1}{2}$ -inch (38.1 mm) RCS lead shafts and extensions are carbon steel plates conform to ASTM A656, Grade 80, and having a minimum yield strength of 80,000 psi (552 MPa) and a minimum tensile strength of 90,000 psi (621 MPa). The helical plates are factory-welded to the shafts and can either be bare steel or hot-dipped galvanized in accordance with ASTM A123.

3.3.3 Extension Shaft Couplers: The extension shaft couplers for the $2\frac{7}{8}$ -inch-outside-diameter (73 mm) piles are carbon steel round tubes that conform to ASTM A1026, except for having a minimum yield strength of 72,000 psi (496 MPa) and a minimum tensile strength of 79,000 psi (545 MPa). The extension shaft couplers for the $3\frac{1}{2}$ -inch-outside-diameter (89 mm) piles are carbon steel round tubes that conform to ASTM A500, Grade C, except for having a minimum yield strength of 80,000 psi (552 MPa) and a minimum tensile strength of 85,000 psi (586 MPa). The $2\frac{7}{8}$ -inch-outside-diameter (73 mm)

and $3\frac{1}{2}$ -inch-outside-diameter (89 mm) extension shaft couplers are factory-welded to the extensions. The $1\frac{1}{2}$ -inch (38.1 mm) extension shaft couplers are forged from the steel bar specified in Section 3.3.1. The extension shaft couplers can either be bare steel or hot-dipped galvanized in accordance with ASTM A123.

3.3.4 Repair Brackets (278CF and 312CF): The plates used to fabricate the repair bracket seat, stiffeners, and lifting T-bracket conform to ASTM A572, Grade 50, and having a minimum yield strength of 50,000 psi (345 MPa) and a minimum tensile strength of 65,000 psi (448 MPa). The lifting T-bracket stem and the sleeve of the seat are round steel tubing which conform to ASTM A500, Grade C, and having a minimum yield strength of 80,000 psi (551 MPa) and a minimum tensile strength of 85,000 psi (586 MPa). The repair brackets can either be bare steel or hot-dipped galvanized in accordance with ASTM A123.

3.3.5 New Construction Brackets (278NC, 312NC, and SQ150NC): The steel bearing plates for 278NC, 312NC, and SQ150NC brackets conform to ASTM A572, Grade 50, and having a minimum yield strength of 50,000 psi (345 MPa) and a minimum tensile strength of 65,000 psi (448 MPa). For the 278NC bracket, the round steel tube sleeve conforms to ASTM A1026, and having a minimum yield strength of 72,000 psi (496 MPa) and a tensile strength of 79,000 psi (545 MPa). For the 312NC bracket, the round steel tube sleeve conforms to ASTM A500, Grade C, and having a minimum yield strength of 80,000 psi (551 MPa) and a tensile strength of 85,000 psi (586 MPa). For the SQ150NC bracket, the round steel tubing conforms to ASTM A500, Grade C, and having a minimum yield strength of 55,000 psi (379 MPa) and a tensile strength of 75,000 psi (517 MPa). The new construction brackets can either be bare steel or hot-dipped galvanized in accordance with ASTM A123.

3.3.6 All Other Fastening Assemblies (Including Brackets): The threaded rods conform to ASTM A307 Grade A. The nuts conform to ASTM A563 Grade A and ASTM A194 Grade 2H. The washers conform to ASTM F844. Through-bolts used to connect the new construction bracket and shaft extensions and lead shafts conform to ASTM A325. Bolts, nuts, washers, and threaded rods can either be bare or hot-dipped galvanized in accordance with ASTM A153.

4.0 DESIGN AND INSTALLATION

4.1 Design:

4.1.1 General: Engineering calculations and drawings, prepared by a registered design professional, must be submitted to the code official for each project, must be based on accepted engineering principles as described in IBC Section 1604.4, and must conform to 2021, 2018, 2015, 2012 and 2009 IBC Section 1810 (2006 IBC Section 1808). The load capacities shown in this report are based on allowable stress design (ASD) described in IBC Section 202 and AISC 360 Section B3. The engineering analysis must address helical foundation system performance related to structural and geotechnical requirements.

The calculations must address the ability (considering strength and stiffness) of the supported foundation and structure to transmit the applied loads to the helical foundation system and the ability of the helical piles and surrounding soils to support the loads applied by the supported foundation and structure. The structural analysis must consider all applicable internal forces (axial, shear, bending moments, and torsional moments, if applicable) due to applied loads, load transfer between the bracket and the pile segments (leads and extensions),

and maximum span(s) between helical foundations. The result of the analysis and the structural capacities must be used to select a helical foundation system. The minimum embedment depth for various loading conditions must be included, based on the most stringent requirements of the following: engineering analysis; tested conditions described in this report; a site-specific geotechnical investigation report; and site-specific load tests, if applicable.

The geotechnical analysis must address the suitability of the helical foundation system for the specific project. It must also address the center-to-center spacing of the helical pile, considering both effects on the supported foundation and structure, and group effects on the pile-soil capacity. The analysis must include estimates of the axial tension and/or compression capacities of the helical piles, whatever is relevant for the project, and the expected total and differential foundation movements due to a single pile or pile group, as applicable.

A soil investigation report (geotechnical report) must be submitted to the code official as part of the required submittal documents, prescribed in 2021, 2018, 2015, 2012, and 2009 IBC Section 107 (2006 IBC Section 106), at the time of permit application. The geotechnical report must include, but is not limited to, all the following:

1. A plot showing the location of the soil investigation.
2. A complete record of the soil boring and penetration test logs and soil samples.
3. A record of soil profile.
4. Information on groundwater table, frost depth, and corrosion-related parameters, as described in Section 5.5 of this report.
5. Soil design parameters, such as: shear strength, soil allowable bearing pressure, unit weight of soil, soil deformation characteristics, and other parameters affecting pile support conditions as defined in 2021, 2018, 2015, 2012 and 2009 IBC Section 1810.2.1 (2006 IBC Section 1808.2.9).
6. Confirmation of the suitability of helical foundation systems for the specific project.
7. Recommendations for design criteria, including, but not be limited to: mitigation of effects of differential settlement, varying soil strength, and effects of adjacent loads.
8. Recommended center-to-center spacing of helical pile foundations, if different from spacing noted in Section 5.14 of this report; and reduction of allowable loads due to the group action, if necessary.
9. Field inspection and reporting procedures to include procedures for verification of the installed bearing capacity, when required.
10. Load test requirements.
11. Any questionable soil characteristics and special design provisions, as necessary.
12. Expected total and differential settlement.
13. The axial compression, axial tension, and lateral load soil capacities, if values cannot be determined from this evaluation report.

The allowable axial compressive or tensile load of the helical pile system must be based on the least of the following in accordance with 2021, 2018, 2015, 2012 and 2009 IBC Section 1810.3.3.1.9:

- P1: Allowable axial capacity of the bracket. Section 4.1.2 of this report includes bracket capacities.
- P2: Allowable axial capacity of pile shaft. Section 4.1.3 of this report includes pile shaft capacities.
- P3: Sum of the allowable axial capacity of helical bearing plates affixed to pile. Section 4.1.4 of this report includes helical plate axial capacities.
- P4: Allowable capacity determined from well-documented correlations with installation torque. Section 4.1.5 of this report includes torque correlation factors used to establish pile axial load capacities based on documented correlations.
- P4: Sum of the areas of the helical bearing plates times the ultimate bearing capacity of the soil or rock comprising the bearing stratum divided by a safety factor of 2. This capacity will be determined by a registered design professional based on site-specific soil conditions.
- P4: Allowable capacity predicted by dividing the ultimate capacity determined from load tests by a safety factor of at least 2.0. This capacity will be determined by a registered design professional for each site-specific condition. Under the 2021 IBC, the load tests must comply with 2021 IBC Section 1810.3.3.1.2.

4.1.2 Bracket Capacity (P1): Tables 1A, 1B, and 1C describe the allowable bracket capacity for new construction brackets (278NC, 312NC, and SQ150NC) and repair brackets (278CF, 312CF). The connections of the building structure to the helical pile brackets must be designed and included in the construction documents. The concrete foundation must be designed and justified to the satisfaction of the code official with due consideration to the eccentricity of applied loads, including reactions provided by the brackets, acting on the concrete foundation. Only localized limit states of steel and supporting concrete foundation, including punching shear and bearing, have been considered in this evaluation report. Other limit states are outside the scope of this evaluation report and must be determined by the registered design professional. The effects of reduced lateral sliding resistance due to uplift from wind or seismic loads must be considered for each project.

4.1.3 Pile Shaft Capacity (P2): Tables 3A, 3B, and 3C describe the shaft allowable capacity. Tables 2A, 2B, and 2C describe the mechanical properties of the shafts, which are based on a 50-year corrosion effect in accordance with Section 3.9 of AC308. The top of the shafts must be braced as described in 2021, 2018, 2015, 2012 and 2009 IBC Section 1810.2.2, and 2006 IBC Section 1808.2.5. In accordance with 2021, 2018, 2015, 2012 and 2009 IBC Section 1810.2.1, and 2006 IBC Section 1808.2.9, any soil other than fluid soil must be deemed to afford sufficient lateral support to prevent buckling of the systems that are braced, and the unbraced length is defined as the length of piles standing in air, water, or in fluid soils plus an additional 5 feet (1524 mm) when embedment is into firm soil, or an additional 10 feet (3048 mm) when embedment is into soft soil. Firm soils must be defined as any soil with a Standard Penetration Test (SPT) blow count of five or greater. Soft soils must be defined as any soil with a SPT blow count greater than zero and less than five. Fluid soils must be defined as any soil with a SPT blow count of zero [weight of hammer (WHO) or weight of rods (WOR)]. Standard Penetration Test blow count must be determined in accordance with ASTM D1586. The shaft capacity of the helical foundation systems in air, water or fluid soils must be determined by a registered design professional using parameters in Tables 2A, 2B, and 2C with due

consideration of lateral support provided by the surrounding soil and/or structure.

The elastic shortening/lengthening of the pile shaft will be controlled by the strength and section properties of the shaft sections and coupler(s). For loads up to and include the allowable load limits found in this report, the elastic shortening/lengthening of a shaft can be estimated as:

$$\Delta_{\text{shaft}} = P L / (A E)$$

where:

Δ_{shaft} = Length change of shaft resulting from elastic shortening/lengthening, in (mm).

P = applied axial load, kip (kN).

L = effective length of the shaft, in. (mm).

A = cross-sectional area of the shaft, see Tables 2A, 2B, and 2C, in.² (mm²).

E = Young's modulus of the shaft, see Table 2A, 2B, and 2C, ksi (MPa).

The slip of the helical pile coupler is 0.161-inch/coupler (4.1 mm/coupler) for 2⁷/₈-inch diameter shafts, 0.286-inch/coupler (7.3 mm/coupler) for 3¹/₂-inch-diameter shafts, and 0.161-inch/coupler (4.1 mm/coupler) for 1¹/₂-inch RCS shafts at rated allowable compression/tensile load per coupling.

4.1.4 Helix Plate Capacity (P3): Tables 4A, 4B, and 4C describe the allowable helical bearing plate capacity. For helical piles with more than one helix, the allowable helix capacity for the helical foundation systems supporting axial compression and tension loads may be taken as the sum of the least allowable capacity of each individual helix. The helix plates are spaced three times the diameter of the lowest plate apart starting at the toe of the lead shaft section and extending into the flighted extensions, if specified.

4.1.5 Soil Capacity (P4): Table 5 describes the geotechnical related properties of the piles. The allowable axial compressive or tensile soils capacity of helical piles (P4) must be determined by a registered design professional in accordance with a site-specific geotechnical report, as described in Section 4.1.1, combined with the individual helix bearing method (Method 1), or from field loading tests conducted under the supervision of a registered design professional (Method 2). For either Method 1 or Method 2, the predicted axial load capacities must be confirmed during the site-specific production installation, such that the axial load capacities predicted by the torque correlation method are equal to or greater than what is predicted by Method 1 or 2, described above.

The individual bearing method is determined as the sum of the individual areas of the helical bearing plates times the ultimate bearing capacity of the soil or rock comprising the bearing stratum. Under the 2021 IBC, the axial capacity is equal to the sum of the areas of the helical bearing plates times the ultimate bearing capacity of the soil or rock comprising the bearing stratum plus the shaft resistance. The shaft resistance is equal to the area of the shaft above the uppermost helical bearing plate times the ultimate skin friction.

The design allowable axial load must be determined by dividing the total ultimate axial load capacity predicted by either Method 1 or 2, above, divided by a safety factor of at least 2.

The torque correlation method must be used to predict the ultimate capacity (Q_{ult}) of the pile and the minimum

installation torque (Equation 1). A factor of safety of 2 must be applied to the ultimate capacity to determine the allowable soil capacity (Q_{all}) of the pile (Equation 2).

$$Q_{ult} = K_t T \quad (\text{Equation 1})$$

$$Q_{all} = 0.5 Q_{ult} \quad (\text{Equation 2})$$

where:

Q_{ult} = Ultimate axial compressive or tensile capacity (lbf or N) of helical pile, which must be limited to the maximum ultimate values noted in Table 5.

Q_{all} = Allowable axial compressive or tensile capacity (lbf or N) of helical pile, which must be limited to the maximum ultimate values noted in Table 5.

K_t = Torque correlation factors are described in Table 5.

T = Final installation torque in (ft-lbf or N-m). The final installation torque is defined as the last torque reading taken during the pile installation, using, for example, the torque reading instruments connected to the installation equipment.

The allowable lateral soil capacity is 1,100 lbf (4.89 kN) for 2⁷/₈-inch diameter helical piles, 1,650 lbf (7.34 kN) for 3¹/₂-inch diameter helical piles, and 475 lbf (2.11 kN) for 1¹/₂-inch RCS helical piles. It is based on field testing of the helical piles with a single 8-inch-diameter (203 mm) helix plate installed in a firm clay soil, having an average standard penetration test blow count of 20, at a minimum embedment of 15 feet (4.57 m). For soil conditions other than firm clay, the lateral capacity of the pile must be determined by a registered design professional.

4.2 Installation:

The Ideal Helical Foundation Systems must be installed by certified and trained installers approved by Ideal Manufacturing Inc. The Ideal Helical Foundation Systems must be installed in accordance with this section (Section 4.2); 2021, 2018, 2015, 2012 and 2009 IBC Section 1810.4.11; the manufacturer's published installation instructions; and approved site-specific construction documents. In case of a conflict, the most stringent requirement governs.

4.2.1 Helical Pile Installation: The helical piles must be installed and located in accordance with the approved plans and specifications. The helical piles are typically installed using hydraulic rotary motors having forward and reverse capabilities, as recommended by Ideal Manufacturing, Inc. In conjunction with rotating the pile, an axial force (crowd sufficient to cause the pile to penetrate the earth at a rate of approximately 3 inches [76.2 mm] per revolution) is also applied. The installation speeds must be limited to less than 25 revolutions per minutes (rpm). The installation torque must not exceed the Maximum Installation Torque Rating, as described in Table 5. Helical piles must be installed vertically into the ground with a maximum allowable angle of inclination of ± 1 degree from vertical. The helical piles must be rotated clockwise in a continuous manner with the lead shaft section advancing at the helix pitch. Extensions and flighted extensions (number and length) are selected based on the approved plans as specified per the site conditions by a registered design professional. The extensions, flighted extensions, and the lead shaft section must be connected by the use of the designed number of coupling bolts and nuts as described in Section 3.2.3. Coupling bolts must be snug-tightened as defined in Section J3 of AISC 360. The final installation torque must

equal or exceed that specified by the torque correlation method. The helical piles must be installed to the minimum depth described in the approved plans, but with the helical plate not less than 5 feet (1.53 m) below the bottom of the supported concrete foundation.

4.2.2 Foundation Attachments:

4.2.2.1 Repair Bracket: The repair bracket must be installed as specified in the approved plans. The repair bracket is installed by excavating the bottom of the footing or foundation and large enough to provide access for bracket installation. The excavation is extended under the footing for 14 inches (356 mm) from chiseled footing face, 12 inches (305 mm) below the footing, and 14 inches (356 mm) parallel with the footing. The face and underside of the footing for the bracket bearing plate is cleaned and chipped if highly irregular, and should be relatively flat. Existing concrete footing capacity must not be altered, such as with notching of concrete or cutting of reinforcing steel, without the approval of the registered design professional and the code official. The repair bracket is installed over the pile shaft, away from the concrete footing. The bracket is rotated into place under the footing and raised into position. The footing face and underside should be fully bearing on the bracket plate. Place non-shrink grout in any small voids between footing, bracket seat and concrete footing. The pile shaft is cut off squarely at least 14 inches (356 mm) up from bottom of footing. This may change depending on the amount of lift. All field-cut or drilled pilings may be protected from corrosion as recommended by the registered design professional and approved by the code official. The T-bracket is installed over the pile shaft, and threaded rods, nuts and washers are added to hold the bracket in position. Coupling nuts, jacking bracket, and lifting jack are installed to raise the foundation to the desired elevation. Any lifting of the existing structure must be verified by a registered design professional and is subject to approval of the code official to ensure that the foundation, superstructure, and helical piles are not overstressed. The bracket can be lifted only after the non-shrink grout placed during bracket installation has cured. Once the foundation has been raised to its desired elevation and the hex nuts over the T-bracket are tightened, then the jacking brackets and lifting jacks are removed. The threaded-rod nuts must be snug-tightened as defined in Section J3 of AISC 360. The excavation must be backfilled in accordance with 2021, 2018, 2015, 2012 and 2009 IBC Section 1804 (2006 IBC Section 1803).

4.2.2.2 New Construction Bracket: New construction brackets must be placed over the top of the helical pile shaft. The top of pile elevation must be established and must be consistent with the specified elevation. If necessary, the top of the pile may be cut off level to the required length in accordance with the manufacturer's instructions and AISC 360 requirements so as to ensure full, direct contact (bearing) between the top of the pile shaft and the bracket. All field-cut or drilled pilings may be protected from corrosion as recommended by the registered design professional and approved by the code official. For new construction brackets 278NC and 312NC installed for tension application, two ¾-inch-diameter (19 mm) bolts and matching nuts as described in Section 3.3.6 of this report must be installed for helical piles in tension. In the case of new construction bracket SQ150NCG60 installed for tension application, one ¾-inch-diameter (19 mm) bolt and matching nut as described in Section 3.3.6 of this report must be installed for helical piles in tension. The bolts must be snug-

tightened as defined in Section J3 of AISC 360. The embedment and edge distance of the bracket into the concrete foundation must be as described in the approved plans and as indicated in Tables 1A, 1B, and 1C of this report. The concrete foundation must be cast around the bracket in accordance with the approved construction documents.

4.3 Special Inspection:

Continuous special inspection in accordance with 2021, 2018, 2015, and 2012 IBC Section 1705.9 (2009 IBC Section 1704.10 and 2006 IBC Section 1704.9) must be provided for the installation of the helical piles and foundation brackets. Where on-site welding is required, special inspection in accordance with 2021, 2018, 2015, and 2012 IBC Section 1705.2 (2009 and 2006 IBC Section 1704.3) is also required. Items to be recorded and confirmed by the special inspector must include, but are not necessarily limited to, the following:

1. Verification of product manufacturer and the manufacturer's certification of the installers.
2. Verification of product types and configurations for helical pile lead shaft sections, extensions, brackets, bolts, threaded rods, nuts, washers, and torque as specified in this report and the construction documents.
3. Installation procedures for helical pile shaft, installation equipment used, and the Ideal Helical Foundation Systems installation instructions.
4. Anticipated and actual piling depth.
5. Required target installation torque of piles and depth of the helical foundation system.
6. Inclination and position of helical piles; top of pile extension in full contact with bracket; tightness of all bolts; and evidence that the helical pile foundation systems are installed by an approved Ideal Helical Foundation Systems installer.
7. Other pertinent installation data as required by the registered professional in responsible charge and compliance of installation with the approved geotechnical report, construction documents, and this evaluation report.

5.0 CONDITIONS OF USE

The Ideal Helical Foundation Systems described in this report comply with, or are suitable alternatives to what is specified in, those codes indicated in Section 1.0 of this report, subject to the following conditions:

- 5.1 The helical pile system is manufactured, identified, and installed in accordance with this report, the approved construction documents, and the manufacturer's published installation instructions, which must be available at the jobsite at all times during installation. In the event of a conflict between this report, the approved construction documents and the manufacturer's published installation instructions, the most restrictive governs.
- 5.2 The helical pile system has been evaluated for support of structures assigned to Seismic Design Categories (SDCs) A, B and C in accordance with IBC. Use of the systems to support structures assigned to SDC D, E, or F are outside the scope of this report, and are subject to the approval of the building official, based upon submission of a design in accordance with the code by a registered design professional.

- 5.3 Both the repair bracket and the new construction bracket must be used only to support structures that are laterally braced as defined in 2021, 2018, 2015, 2012 and 2009 IBC Section 1810.2.2 (2006 IBC Section 1808.2.5). Shaft couplings must be located within firm or soft soil as defined in Section 4.1.3.
- 5.4 Installation of the helical foundation systems is limited to support of uncracked normal-weight concrete, as determined in accordance with the applicable code.
- 5.5 Use of the helical foundation systems in exposure conditions that are indicative of potential pile deterioration or corrosion situations, as defined by the following: (1) soil resistivity less than 1,000 ohm-cm; (2) soil pH less than 5.5; (3) soils with high organic content; (4) soil sulfate concentrations greater than 1,000 ppm; (5) soils located in landfill; or (6) soil containing mine waste is beyond the scope of the evaluation report.
- 5.6 Zinc-coated steel and bare steel components must not be combined in the same system; unless, they are designed as bare steel elements. All helical foundation components must be galvanically isolated from concrete reinforcing steel, building structural steel, or any other metal building components.
- 5.7 Special inspection is provided in accordance with Section 4.3 of this report.
- 5.8 The helical piles must be installed vertically into the ground with a maximum allowable angle of inclination of 1 degree from vertical. To comply with the requirements found in 2021, 2018, 2015, 2012 and 2009 IBC Section 1810.3.1.3 (2006 IBC Section 1808.2.8.8), the superstructure must be designed to resist the effects of helical pile eccentricity.
- 5.9 A soil investigation (geotechnical report) in accordance with Section 4.1.1 of this report must be submitted to the code official for approval.
- 5.10 The load combinations prescribed in 2021 IBC Section 1605.1 (2018, 2015, 2012, 2009, and 2006 IBC Section 1605.3.1) must be used to determine the applied loads. When using the alternative basic load combinations prescribed in the 2021 IBC Section 1605.2 (2018, 2015, 2012, 2009, and 2006 IBC Section 1605.3.2), the allowable stress increases permitted by material chapters of the IBC (Chapters 19 through 23, as applicable) or the referenced standards are prohibited.
- 5.11 Engineering calculations and drawings must be in accordance with recognized engineering principles as described in IBC Section 1604.4, in compliance with Section 4.1 of this report, prepared by a registered design professional and approved by the code official.
- 5.12 The applied loads must not exceed the allowable capacities described in Section 4.1 of this report.
- 5.13 The adequacy of the concrete structures that are connected to the brackets must be verified by a registered design professional in accordance with applicable code provisions, and is subject to the approval of the code official.
- 5.14 In order to avoid group efficiency effects, an analysis prepared by a registered design professional must be submitted where the center-to-center spacing of axially loaded helical piles is less than three times

the diameter of the largest helix plate at the depth of bearing. An analysis prepared by a registered design professional must also be submitted where the center-to-center spacing of laterally loaded helical piles is less than eight times the least horizontal dimension of the pile shaft at the ground surface. For laterally loaded piles, spacing between helical plates must not be less than $3D$, where D is the diameter of the largest helical plate measured from the edge of the helical plate to the edge of the helical plate of the adjacent helical pile; or $4D$, where the spacing is measured from the center-to-center of the adjacent helical pile plates.

- 5.15 Compliance with 2021, 2018, 2015, 2012 and 2009 IBC Section 1810.3.11.1 (2006 IBC Section 1808.2.23.1.1) for buildings assigned to Seismic Design Category (SDC) C, and with 2021, 2018, 2015, 2012, and 2009 IBC Section 1810.3.6 (2006 IBC Section 1808.2.7) for all buildings, is outside the scope of this report. Such compliance must be addressed by a registered design professional for each site, and is subject to approval by the code official.
- 5.16 For tension applications, the pile shall be installed such that the minimum depth from the ground surface to the uppermost helix is $12D$, where D is the diameter of the largest helix. In cases where the installation depth is less than $12D$, the minimum embedment depth shall be determined by a registered design professional based on site-specific soil conditions, which must be subject to the approval of the code official. For tension applications where the helical pile is installed at an embedment depth less than $12D$, the torque-correlation soil capacity, P_4 , is outside the scope of this report.
- 5.17 Settlement of the helical pile is outside the scope of this report and must be determined by a registered design professional, as required in 2021, 2018, 2015, 2012 and 2009 IBC Section 1810.2.3 (2006 IBC Section 1808.2.12).
- 5.18 The Ideal Helical Foundation Systems are manufactured at the Ideal Manufacturing, Inc., facility located in Webster, New York, under a quality-control program with inspections by ICC-ES.

6.0 EVIDENCE SUBMITTED

Data in accordance with the ICC-ES Acceptance Criteria for Helical Pile Systems and Devices (AC358), dated June 2020 (editorially revised March 2021).

7.0 IDENTIFICATION

- 7.1 The Ideal Helical Foundation System components must be identified by a tag or label bearing the name and address of Ideal Manufacturing Inc., the catalog number, ICC-ES mark of conformity, and the evaluation report number (ESR-3750). The evaluation report number ICC-ES ESR-3750, may be used in lieu of the mark of conformity.
- 7.2 The report holder's contact information is the following:

IDEAL MANUFACTURING, INC.
999 PICTURE PARKWAY
WEBSTER, NEW YORK 14580
(585) 872-7190
www.idealfoundationsystems.com
info@idl-grp.com

TABLE 1A—BRACKET CAPACITY (P1) FOR SIDE LOAD AND DIRECT LOAD BRACKETS USED WITH 2⁷/₈-INCH SHAFTS^{5,7}

PRODUCT NUMBER	DESCRIPTION	SHAFT DIAMETER (inches)	ALLOWABLE CAPACITY (kips)		
			Compression	Tension	Lateral
278CF	Repair Bracket	2 ⁷ / ₈	29.4 ¹	N/A	N/A
278NC	New Construction Bracket	2 ⁷ / ₈	58.1 ²	40.8 ^{3,6}	1.0 ⁴

For SI: 1 inch = 25.4 mm, 1 kip (1000 lbf) = 4.48 kN.

¹Load capacity is based on full scale load tests per AC358 with an installed 5'-0" unbraced pile length having a maximum of one coupling per 2021, 2018, 2015, 2012 and 2009 IBC Section 1810.2.1 and 2006 IBC 1808.2.9.2. Repair brackets must be concentrically loaded and the bracket plate must be fully engaged with bottom of concrete foundation. Only localized limit states such as mechanical strength of steel components and concrete bearing have been evaluated. Minimum specified compressive strength of concrete is 3,000 psi (20.68 MPa).

²The allowable compressive load capacity is based on the mechanical strength of the steel bracket, concrete punching shear capacity, and concrete bearing strength. The allowable load capacities have been determined assuming that minimum reinforcement has been provided as specified by ACI 318-19 & -14 Section 9.6.1.2, and ACI 318-11 Section 10.5.1. The minimum embedment of the bracket is 12.6 inches. The embedment depth is the distance between the top of the bracket plate to the top of the concrete footing. End of helical pile shaft must be fully bearing on bracket plate. The concrete footing must have a minimum width of 33.2 inches, and must be normal-weight concrete having a minimum compressive strength of 2,500 psi.

³The allowable tensile load capacity is based on the mechanical strength of the steel bracket, punching shear capacity and bearing to concrete footing. The allowable load capacities have been determined assuming that minimum reinforcement has been provided as specified by ACI 318-19 & -14 Section 9.6.1.2 and ACI 318-11 Section 10.5.1. The minimum embedment of the bracket is 12.11 inches. The embedment depth is the distance between the bottom of the bracket plate to the bottom of the concrete footing. The capacity is based using two ¾-inch through bolts as described in Section 3.2.4.2 of this report. The concrete footing must have a minimum width of 28.2 inches, and must be normal-weight concrete having a minimum compressive strength of 2,500 psi.

⁴The allowable lateral capacity is based on limit states associated with mechanical steel strength, concrete breakout in accordance with ACI 318, and bracket bearing on unreinforced concrete in accordance with ACI 318. The bracket must be installed with a minimum embedment depth of 4 inches measured from the bottom of the bracket plate to the bottom of the concrete footing, and a minimum edge distance of 6.5 inches measured from the bracket plate edge to the concrete footing edge. The concrete footing must have a minimum width of 21 inches, and must be normal-weight concrete having a minimum compressive strength of 2,500 psi.

⁵The capacities listed in Table 1A assume the pile foundation system is sidesway braced per 2021, 2018, 2015, 2012 and 2009 IBC Section 1810.2.2 and 2006 IBC Section 1808.2.5.

⁶ The bolt threads are excluded from the connection shear plane.

⁷ Allowable capacities are based on bare steel losing 0.036-inch (318 µm) steel thickness as indicated in Section 3.9 of AC358 for a 50-year service life.

N/A = not applicable.

TABLE 1B—BRACKET CAPACITY (P1) FOR SIDE LOAD AND DIRECT LOAD BRACKETS USED WITH 3¹/₂-INCH SHAFTS^{5,7}

PRODUCT NUMBER	DESCRIPTION	SHAFT DIAMETER (inches)	ALLOWABLE CAPACITY (kips)		
			Compression	Tension	Lateral
312CF	Repair Bracket	3 ¹ / ₂	38.2 ¹	N/A	N/A
312NC	New Construction Bracket	3 ¹ / ₂	60.0 ²	43.2 ^{3,6}	1.0 ⁴

For **SI**: 1 inch = 25.4 mm, 1 kip (1000 lbf) = 4.48 kN.

¹Load capacity is based on full scale load tests per AC358 with an installed 5'-0" unbraced pile length having a maximum of one coupling per 2021, 2018, 2015, 2012 and 2009 IBC Section 1810.2.1 and 2006 IBC 1808.2.9.2. Repair brackets must be concentrically loaded and the bracket plate must be fully engaged with bottom of concrete foundation. Only localized limit states such as mechanical strength of steel components and concrete bearing have been evaluated. Minimum specified compressive strength of concrete is 3,000 psi (20.68 MPa).

²The allowable compressive load capacity is based on the mechanical strength of the steel bracket, concrete punching shear capacity, and concrete bearing strength. The allowable load capacities have been determined assuming that minimum reinforcement has been provided as specified by ACI 318-19 & -14 Section 9.6.1.2 and ACI 318-11 Section 10.5.1. The minimum embedment of the bracket is 15.0 inches. The embedment depth is the distance between the top of the bracket plate to the top of the concrete footing. End of helical pile shaft must be fully bearing on bracket plate. The concrete footing must have a minimum width of 38 inches, and must be normal-weight concrete having a minimum compressive strength of 2,500 psi.

³The allowable tensile load capacity is based on the mechanical strength of the steel bracket, punching shear capacity and bearing to concrete footing. The allowable load capacities have been determined assuming that minimum reinforcement has been provided as specified by ACI 318-19 & -14 Section 9.6.1.2 and ACI 318-11 Section 10.5.1. The minimum embedment of the bracket is 12.5 inches. The embedment depth is the distance between the bottom of the bracket plate to the bottom of the concrete footing. The capacity is based using two ¾-inch through bolts as described in Section 3.2.4.2 of this report. The concrete footing must have a minimum width of 28.9 inches, and must be normal-weight concrete having a minimum compressive strength of 2,500 psi.

⁴The allowable lateral capacity is based on limit states associated with mechanical steel strength, concrete breakout in accordance with ACI 318, and bracket bearing on unreinforced concrete in accordance with ACI 318. The bracket must be installed with a minimum embedment depth of 4 inches measured from the bottom of the bracket plate to the bottom of the concrete footing, and a minimum edge distance of 6.5 inches measured from the bracket plate edge to the concrete footing edge. The concrete footing must have a minimum width of 21 inches, and must be normal-weight concrete having a minimum compressive strength of 2,500 psi.

⁵The capacities listed in Table 1B assume the pile foundation system is sidesway braced per 2021, 2018, 2015, 2012 and 2009 IBC Section 1810.2.2 and 2006 IBC Section 1808.2.5.

⁶ The bolt threads are excluded from the connection shear plane.

⁷ Allowable capacities are based on bare steel losing 0.036-inch (318 µm) steel thickness as indicated in Section 3.9 of AC358 for a 50-year service life.

N/A = not applicable.

TABLE 1C—BRACKET CAPACITY (P1) FOR SIDE LOAD AND DIRECT LOAD BRACKETS USED WITH 1¹/₂-INCH RCS SHAFTS^{4,6}

PRODUCT NUMBER	DESCRIPTION	SHAFT DIAMETER (inches)	ALLOWABLE CAPACITY (kips)		
			Compression	Tension	Lateral
SQ150NC	New Construction Bracket	1 ¹ / ₂	52.3 ¹	4.4 ^{2,5}	0.91 ³

For **SI**: 1 inch = 25.4 mm, 1 kip (1000 lbf) = 4.48 kN.

¹The allowable compressive load capacity is based on the mechanical strength of the steel bracket, concrete punching shear capacity, and concrete bearing strength. The allowable load capacities have been determined assuming that minimum reinforcement has been provided as specified by ACI 318-19 & -14 Section 9.6.1.2 and ACI 318-11 Section 10.5.1. The minimum embedment of the bracket is 11.8 inches. The embedment depth is the distance between the top of the bracket plate to the top of the concrete footing. End of helical pile shaft must be fully bearing on bracket plate. The concrete footing must have a minimum width of 31.6 inches, and must be normal-weight concrete having a minimum compressive strength of 2,500 psi.

²The allowable tensile load capacity is based on the mechanical strength of the steel bracket, punching shear capacity and bearing to concrete footing. The allowable load capacities have been determined assuming that minimum reinforcement has been provided as specified by ACI 318-19 & -14 Section 9.6.1.2 and ACI 318-11 Section 10.5.1. The minimum embedment of the bracket is 4 inches. The embedment depth is the distance between the bottom of the bracket plate to the bottom of the concrete footing. The capacity is based using one ¾-inch through bolt as described in Section 3.3.4 of this report. The concrete footing must have a minimum width of 12 inches, and must be normal-weight concrete having a minimum compressive strength of 2,500 psi.

³The allowable lateral capacity is based on limit states associated with mechanical steel strength, concrete breakout in accordance with ACI 318, and bracket bearing on unreinforced concrete in accordance with ACI 318. The bracket must be installed with a minimum embedment depth of 4 inches measured from the bottom of the bracket plate to the bottom of the concrete footing, and a minimum edge distance of 4 inches measured from the bracket plate edge to the concrete footing edge. The concrete footing must have a minimum width of 16 inches, and must be normal-weight concrete having a minimum compressive strength of 2,500 psi.

⁴The capacities listed in Table 1C assume the pile foundation system is sidesway braced per 2021, 2018, 2015, 2012 and 2009 IBC Section 1810.2.2 and 2006 IBC Section 1808.2.5.

⁵ The bolt threads are excluded from the connection shear plane.

⁶ Allowable capacities are based on bare steel losing 0.036-inch (318 µm) steel thickness as indicated in Section 3.9 of AC358 for a 50-year service life.

TABLE 2A—MECHANICAL PROPERTIES AFTER CORROSION LOSS OF 2⁷/₈-INCH DIAMETER HELICAL SHAFT¹

Mechanical Properties	SHAFT DIAMETER	
	2 ⁷ / ₈ -inch (0.203-inch wall thickness)	2 ⁷ / ₈ -inch (0.276-inch wall thickness)
Steel Yield Strength, F _y (ksi)	80	80
Steel Ultimate Strength, F _u (ksi)	85	85
Modulus of Elasticity, E (ksi)	29,000	29,000
Nominal Wall Thickness (inch)	0.203	0.276
Design Wall Thickness (inch)	0.153	0.221
Outside Diameter (inch)	2.839	2.839
Inside Diameter (inch)	2.533	2.398
Cross Sectional Area (inch ²)	1.29	1.82
Moment of Inertia, I (inch ⁴)	1.17	1.57
Radius of Gyration, r (inch)	0.95	0.93
Section Modulus, S (inch ³)	0.82	1.10
Plastic Section Modulus, Z (inch ³)	1.10	1.52

For SI: 1 inch = 25.4 mm; 1 ksi = 6.89 MPa, 1 ft-lbf = 1.36 N-m; 1 lbf = 4.45 N.

¹Dimensional properties are based on bare steel losing 0.036-inch steel thickness as indicated in Section 3.9 of AC358 for a 50-year service life.

TABLE 2B—MECHANICAL PROPERTIES AFTER CORROSION LOSS¹ OF 3¹/₂-INCH DIAMETER HELICAL SHAFT

Mechanical Properties	SHAFT DIAMETER	
	3 ¹ / ₂ -inch (0.216-inch wall thickness)	3 ¹ / ₂ -inch (0.300-inch wall thickness)
Steel Yield Strength, F _y (ksi)	80	80
Steel Ultimate Strength, F _u (ksi)	85	85
Modulus of Elasticity, E (ksi)	29,000	29,000
Nominal Wall Thickness (inch)	0.216	0.300
Design Wall Thickness (inch)	0.165	0.243
Outside Diameter (inch)	3.464	3.464
Inside Diameter (inch)	3.134	2.978
Cross Sectional Area (inch ²)	1.71	2.46
Moment of Inertia, I (inch ⁴)	2.33	3.21
Radius of Gyration, r (inch)	1.17	1.14
Section Modulus, S (inch ³)	1.35	1.85
Plastic Section Modulus, Z (inch ³)	1.80	2.53

For SI: 1 inch = 25.4 mm; 1 ksi = 6.89 MPa, 1 ft-lbf = 1.36 N-m; 1 lbf = 4.45 N.

¹Dimensional properties are based on bare steel losing 0.036-inch steel thickness as indicated in Section 3.9 of AC358 for a 50-year service life.

**TABLE 2C—MECHANICAL PROPERTIES AFTER CORROSION
LOSS OF 1½-INCH RCS HELICAL SHAFT^{1,2}**

Mechanical Properties	SHAFT SIZE
	1½-inch RCS
Steel Yield Strength, F _y (ksi)	90
Steel Ultimate Strength, F _u (ksi)	129
Modulus of Elasticity, E (ksi)	29,000
Nominal Shaft Depth (inch)	1.5
Design Shaft Depth (inch)	1.464
Cross Sectional Area (inch ²)	2.10
Moment of Inertia, I (inch ⁴)	0.361
Radius of Gyration, r (inch)	0.415
Section Modulus, S (inch ³)	0.385
Plastic Section Modulus, Z (inch ³)	0.656

For SI: 1 inch = 25.4 mm; 1 ksi = 6.89 MPa, 1 ft-lbf = 1.36 N-m; 1 lbf = 4.45 N.

¹Dimensional properties are based on bare steel losing 0.036-inch steel thickness as indicated in Section 3.9 of AC358 for a 50-year service life.

²Rounded corners are ¼-inch radius.

**TABLE 3A—SHAFT ALLOWABLE CAPACITY (P2) FOR 2⅞-INCH-DIAMETER PILE
WITH COUPLER ECCENTRICITY^{3,4,5} (kips)**

SHAFT TYPE	UNBRACED SHAFT LENGTH, L _u (FT) ¹	(P2) ALLOWABLE CAPACITY (KIPS) FOR 2⅞-INCH DIAMETER SHAFTS					
		COMPRESSION (KIPS)			TENSION (KIPS)	LATERAL SHEAR (KIPS)	BENDING MOMENT (KIPS-FT)
		0 Coupler	1 Coupler ²	2 Couplers ²			
2⅞-inch OD (0.203-inch wall thickness)	0	60.0	60.0	60.0	23.6	13.3	4.41
	5	25.4	20.8	13.5			
	10	11.4	10.4	8.2			
2⅞-inch OD (0.276-inch wall thickness)	0	60.0	60.0	60.0	34.1	18.6	6.05
	5	35.1	29.6	20.0			
	10	15.4	14.3	11.6			

For SI: 1 inch = 25.4 mm; 1 ft = 0.305 m; 1 kip (1000 lbf) = 4.48 kN.

¹L_u=Total unbraced pile length per 2021, 2018, 2015, 2012 and 2009 IBC Section 1810.2.1 and 2006 IBC Section 1808.2.9.2, including the length in air, water or in fluid soils, and the embedment length into firm or soft soil (non-fluid soil). k = Effective length factor. kL_u = total effective unbraced length of the pile, where kL_u = 0 represent a fully braced condition in that the total pile length is fully embedded in firm or soft soil and the supported structure is braced in accordance 2021, 2018, 2015, 2012 and 2009 IBC Section 1810.2.2 (Section 1808.2.5 of the 2006 IBC).

²Number of couplings within L_u

³The capacities shown in Table 3A are for 2⅞-inch-diameter pilings installed with a maximum 1 degree of inclination and the assumption that the pile shaft is concentrically loaded.

⁴Capacities based on two ¾-inch bolts with matching nuts installed complying with Section 3.3.6. The bolt threads are excluded from the connection shear plane.

⁵Allowable capacities are based on bare steel losing 0.036-inch (318 μm) steel thickness as indicated in Section 3.9 of AC358 for a 50-year service life.

TABLE 3B—SHAFT ALLOWABLE CAPACITY (P2) FOR 3¹/₂-INCH-DIAMETER PILE WITH COUPLER ECCENTRICITY^{3,4,5} (kips)

SHAFT TYPE	UNBRACED SHAFT LENGTH, L _u (FT) ¹	(P2) ALLOWABLE CAPACITY (KIPS) FOR 3 ¹ / ₂ -INCH DIAMETER SHAFTS					
		COMPRESSION (KIPS)			TENSION (KIPS)	LATERAL SHEAR (KIPS)	BENDING MOMENT (KIPS-FT)
		0 Coupler	1 Coupler ²	2 Couplers ²			
3 ¹ / ₂ -inch OD (0.216-inch wall thickness)	0	60.0	60.0	60.0	37.2	17.8	7.1
	5	38.9	28.1	19.8			
	10	20.6	17.1	13.6			
3 ¹ / ₂ -inch OD (0.300-inch wall thickness)	0	60.0	60.0	60.0	37.2	25.5	10.0
	5	55.2	47.5	31.7			
	10	28.7	26.5	20.8			

For **SI**: 1 inch = 25.4 mm; 1 ft = 0.305 m; 1 kip (1000 lbf) = 4.48 kN.

¹L_u=Total unbraced pile length per 2021, 2018, 2015, 2012 and 2009 IBC Section 1810.2.1 and 2006 IBC Section 1808.2.9.2, including the length in air, water or in fluid soils, and the embedment length into firm or soft soil (non-fluid soil). k = Effective length factor. kL_u = total effective unbraced length of the pile, where kL_u = 0 represent a fully braced condition in that the total pile length is fully embedded in firm or soft soil and the supported structure is braced in accordance 2021, 2018, 2015, 2012 and 2009 IBC Section 1810.2.2 (Section 1808.2.5 of the 2006 IBC).

²Number of couplings within L_u

³The capacities shown in Table 3B are for 3¹/₂-inch-diameter pilings installed with a maximum 1 degree of inclination and the assumption that the pile shaft is concentrically loaded.

⁴Capacities based on two 3/4-inch bolts with matching nuts installed complying with Section 3.3.6. The bolt threads are excluded from the connection shear plane.

⁵Allowable capacities are based on bare steel losing 0.036-inch (318 μm) steel thickness as indicated in Section 3.9 of AC308 for a 50-year service life.

TABLE 3C—ALLOWABLE COMPRESSION CAPACITY of 1¹/₂-INCH-DIAMETER PILE WITH COUPLER ECCENTRICITY^{3,4,5} (kips)

SHAFT TYPE	UNBRACED SHAFT LENGTH, L _u (FT) ¹	(P2) ALLOWABLE CAPACITY (KIPS) FOR 1 ¹ / ₂ -INCH RCS SHAFTS					
		COMPRESSION (KIPS)			TENSION (KIPS)	LATERAL SHEAR (KIPS)	BENDING MOMENT (KIPS-FT)
		0 Coupler	1 Coupler ²	2 Couplers ²			
1 ¹ / ₂ -inch RCS	0	60.0	60.0	60.0	15.5	18.7	2.7
	5	13.6	11.0	6.8			
	10	4.3	3.7	3.1			

For **SI**: 1 inch = 25.4 mm; 1 ft = 0.305 m; 1 kip (1000 lbf) = 4.48 kN.

¹L_u=Total unbraced pile length per 2021, 2018, 2015, 2012 and 2009 IBC Section 1810.2.1 and 2006 IBC Section 1808.2.9.2, including the length in air, water or in fluid soils, and the embedment length into firm or soft soil (non-fluid soil). k = Effective length factor. kL_u = total effective unbraced length of the pile, where kL_u = 0 represent a fully braced condition in that the total pile length is fully embedded in firm or soft soil and the supported structure is braced in accordance 2021, 2018, 2015, 2012 and 2009 IBC Section 1810.2.2 (Section 1808.2.5 of the 2006 IBC).

²Number of couplings within L_u

³The capacities shown in Table 3C are for 1¹/₂-inch-RCS pilings installed with a maximum 1 degree of inclination and the assumption that the pile shaft is concentrically loaded.

⁴Capacities based on one 3/4-inch bolt with matching nut installed complying with Section 3.3.6. The bolt threads are excluded from the connection shear plane.

⁵Allowable capacities are based on bare steel losing 0.036-inch (318 μm) steel thickness as indicated in Section 3.9 of AC308 for a 50-year service life.

TABLE 4A—HELICAL BEARING PLATE CAPACITY (P3) FOR 2⁷/₈-INCH HELICAL PILES^{1,2,3}

HELIX DIAM. (IN)	SHAFT TYPE	HELIX THICKNESS (IN)	HELIX PITCH (IN)	ALLOWABLE CAPACITY ³ (P3) (KIPS)
8	2.875-inch (0.203-inch wall and 0.276-inch wall)	0.5	3.0	59.7
10	2.875-inch (0.203-inch wall and 0.276-inch wall)	0.5	3.0	49.3
12	2.875-inch (0.203-inch wall and 0.276-inch wall)	0.5	3.0	39.7
14	2.875-inch (0.203-inch wall and 0.276-inch wall)	0.5	3.0	48.0

For SI: 1 inch = 25.4 mm, 1 kip = 4.448 kN.

¹For helical piles with more than one helix, the allowable helix capacity, P3, for the helical foundation systems, may be taken as the sum of the least allowable capacity of each individual helix.

²As described in Section 3.2.2 of this report, all helical bearing plates are made from same material, and have the same edge geometry, thickness and pitch.

³Allowable capacities are based on bare steel losing 0.036-inch (318 µm) steel thickness as indicated in Section 3.9 of AC358 for a 50-year service life.

TABLE 4B—HELICAL BEARING PLATE CAPACITY (P3) FOR 3¹/₂-INCH HELICAL PILES^{1,2,3}

HELIX DIAM. (IN)	SHAFT TYPE	HELIX THICKNESS (IN)	HELIX PITCH (IN)	ALLOWABLE CAPACITY ³ (P3) (KIPS)
8	3.5-inch (0.216-inch wall and 0.300-inch wall)	0.5	3.0	77.5
10	3.5-inch (0.216-inch wall and 0.300-inch wall)	0.5	3.0	60.8
12	3.5-inch (0.216-inch wall and 0.300-inch wall)	0.5	3.0	63.1
14	3.5-inch (0.216-inch wall and 0.300-inch wall)	0.5	3.0	56.4

For SI: 1 inch = 25.4 mm, 1 kip = 4.448 kN.

¹For helical piles with more than one helix, the allowable helix capacity, P3, for the helical foundation systems, may be taken as the sum of the least allowable capacity of each individual helix.

²As described in Section 3.2.2 of this report, all helical bearing plates are made from same material, and have the same edge geometry, thickness and pitch.

³Allowable capacities are based on bare steel losing 0.036-inch (318 µm) steel thickness as indicated in Section 3.9 of AC358 for a 50-year service life.

TABLE 4C—HELICAL BEARING PLATE CAPACITY (P3) FOR 1¹/₂-INCH RCS HELICAL PILES^{1,2,3}

HELIX DIAM. (IN)	SHAFT TYPE	HELIX THICKNESS (IN)	HELIX PITCH (IN)	ALLOWABLE CAPACITY ³ (P3) (KIPS)
8	1.5-inch RCS	0.375	3.0	22.7
10	1.5-inch RCS	0.375	3.0	20.1
12	1.5-inch RCS	0.375	3.0	26.8
14	1.5-inch RCS	0.375	3.0	25.8

For SI: 1 inch = 25.4 mm, 1 kip = 4.448 kN.

¹For helical piles with more than one helix, the allowable helix capacity, P3, for the helical foundation systems, may be taken as the sum of the least allowable capacity of each individual helix.

²As described in Section 3.2.1 of this report, all helical bearing plates are made from same material, and have the same edge geometry, thickness and pitch.

³Allowable capacities are based on bare steel losing 0.036-inch (318 µm) steel thickness as indicated in Section 3.9 of AC358 for a 50-year service life.

TABLE 5—SOIL CAPACITY (P4) – AXIAL TENSION AND COMPRESSION¹

HELICAL PILE SIZE		GEOTECHNICAL RELATED PROPERTIES	COMPRESSION	TENSION
Shaft's Outer Diameter (in.)	Shaft's Wall Thickness (in.)			
2 ⁷ / ₈	0.203	Maximum Installation Torque Rating (ft-lbs)	8,300	8,300
		Torque Correlation Factor, K _t (ft ⁻¹)	9.0	7.0
		Maximum Ultimate Soil Capacity / Maximum Allowable Soil Capacity (P4) from Torque Correlations (kips) ²	74.7/37.4	58.1/29.1
	0.276	Maximum Installation Torque Rating (ft-lbs)	9,900	9,900
		Torque Correlation Factor, K _t (ft ⁻¹)	9.0	7.0
		Maximum Ultimate Soil Capacity / Maximum Allowable Soil Capacity (P4) from Torque Correlations (kips) ²	89.0/44.5	69.3/34.6
3 ¹ / ₂	0.216	Maximum Installation Torque Rating (ft-lbs)	13,400	13,400
		Torque Correlation Factor, K _t (ft ⁻¹)	7.0	6.5
		Maximum Ultimate Soil Capacity / Maximum Allowable Soil Capacity (P4) from Torque Correlations (kips) ²	93.8/46.9	87.1/43.5
	0.300	Maximum Installation Torque Rating (ft-lbs)	17,200	17,200
		Torque Correlation Factor, K _t (ft ⁻¹)	7.0	6.5
		Maximum Ultimate Soil Capacity / Maximum Allowable Soil Capacity (P4) from Torque Correlations (kips) ²	114.0/57.0	110.5/55.3
1 ¹ / ₂ (RCS)	N/A	Maximum Installation Torque Rating (ft-lbs)	6,980	6,980
		Torque Correlation Factor, K _t (ft ⁻¹)	10	8.5
		Maximum Ultimate Soil Capacity / Maximum Allowable Soil Capacity (P4) from Torque Correlations (kips) ²	69.8/34.9	56.0/28.0

For **SI**: 1 foot = 0.305 m, 1 lbf = 4.448 N, 1 lbf-ft = 1.356 N-m.

¹Soil capacity (P4) must be determined per Section 4.1.5 of this report.

²Maximum ultimate soil capacity is determined from $P_{ult} = K_t \times T$ based on the corresponding maximum installation torque rating for the specific pile model. Allowable soil capacity is determined from $P_a = P_{ult} / 2.0$ based on the corresponding maximum installation torque rating for the specific pile model. See Section 4.1.5 for additional information.

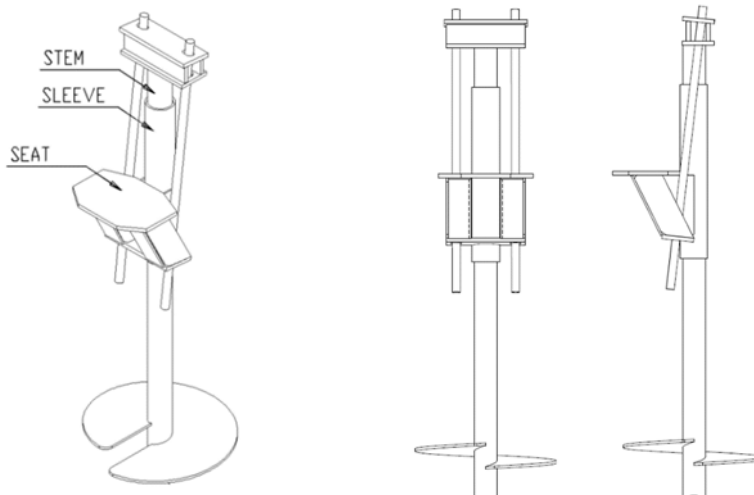

FIGURE 1A—FOUNDATION REPAIR BRACKET (278CF) FOR 2⁷/₈-INCH-DIAMETER SHAFTS

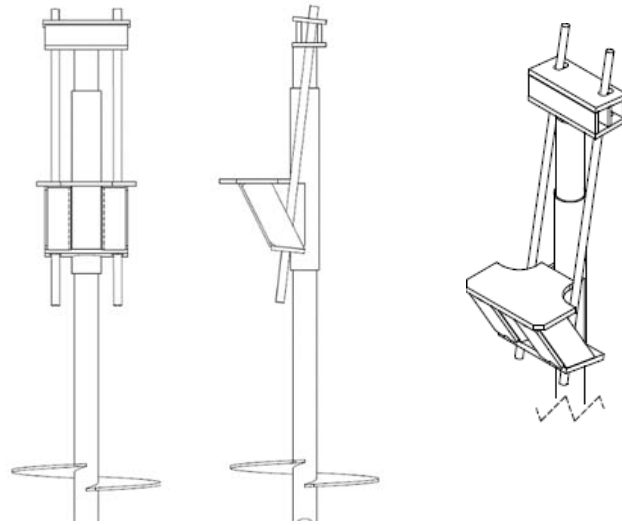

FIGURE 1B—FOUNDATION REPAIR BRACKET (312CF) FOR 3 1/2-INCH-DIAMETER SHAFTS

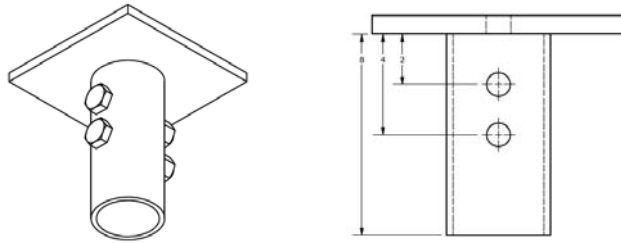

FIGURE 2A—NEW CONSTRUCTION BRACKET FOR 2 7/8 AND 3 1/2-INCH-DIAMETER PILES

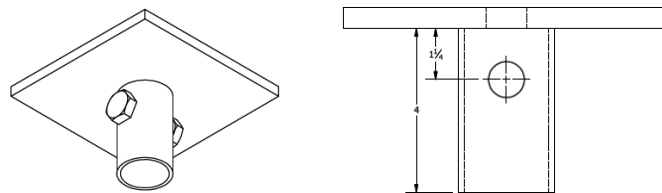

FIGURE 2B—NEW CONSTRUCTION BRACKET FOR 1 1/2-INCH RCS PILES

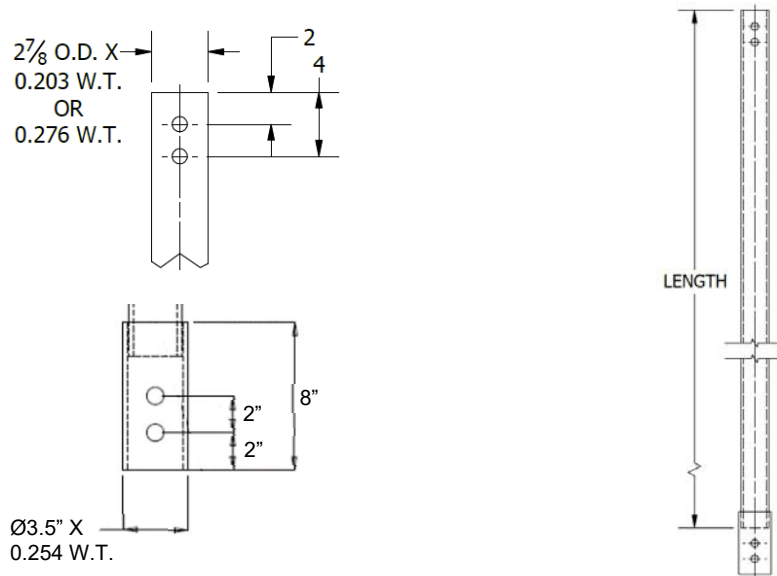

FIGURE 3A—TYPICAL 2 7/8-INCH-DIAMETER EXTENSION SHAFT SECTION

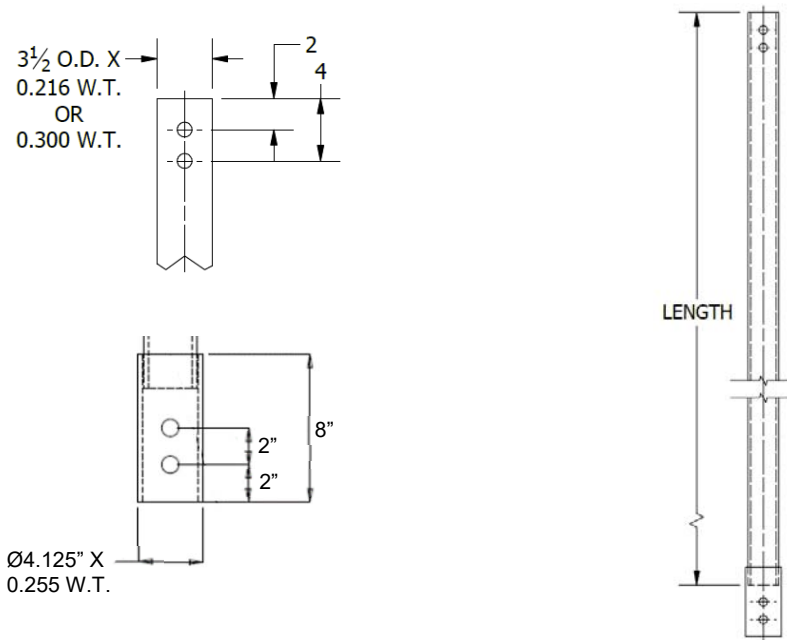

FIGURE 3B—TYPICAL 3 1/2-INCH-DIAMETER EXTENSION SHAFT SECTION

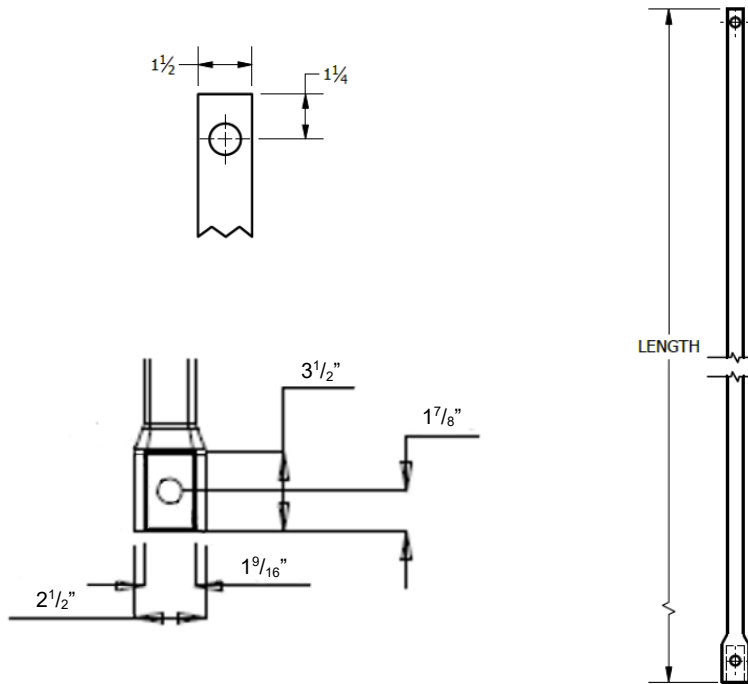

FIGURE 3C—TYPICAL 1 1/2-INCH RCS EXTENSION SHAFT SECTION

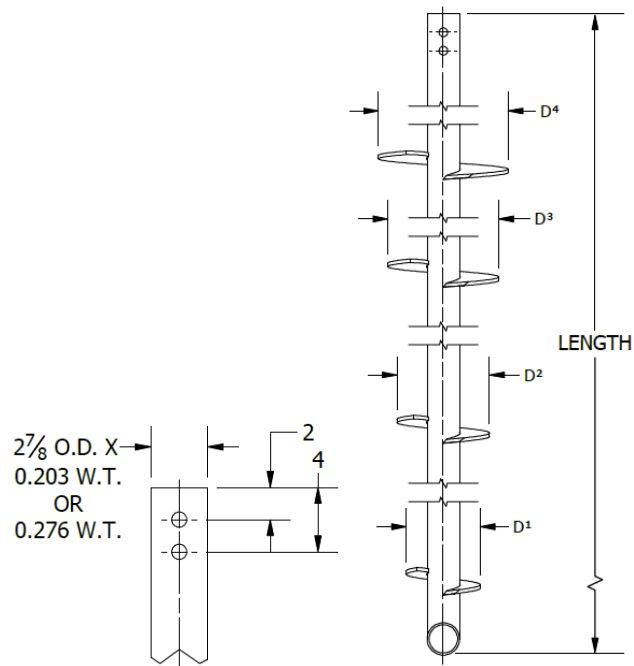

FIGURE 4A—TYPICAL 2 7/8-INCH-DIAMETER HELICAL LEAD SHAFT SECTION AND HELICAL PLATES

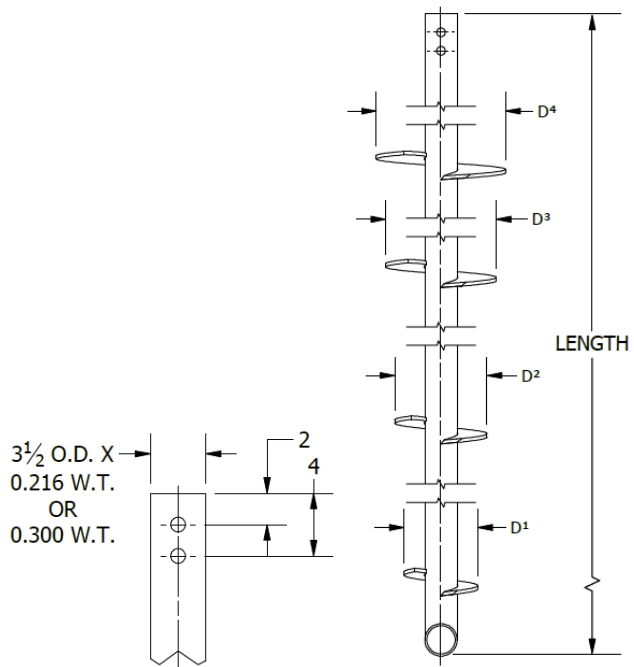

FIGURE 4B—TYPICAL 3 1/2-INCH-DIAMETER HELICAL LEAD SHAFT SECTION AND HELICAL PLATES

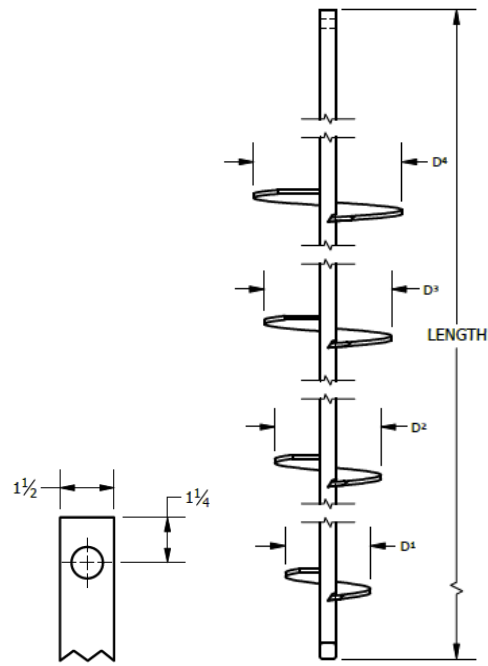

FIGURE 4C—TYPICAL 1 1/2-INCH RCS LEAD SHAFT SECTION AND HELICAL PLATES

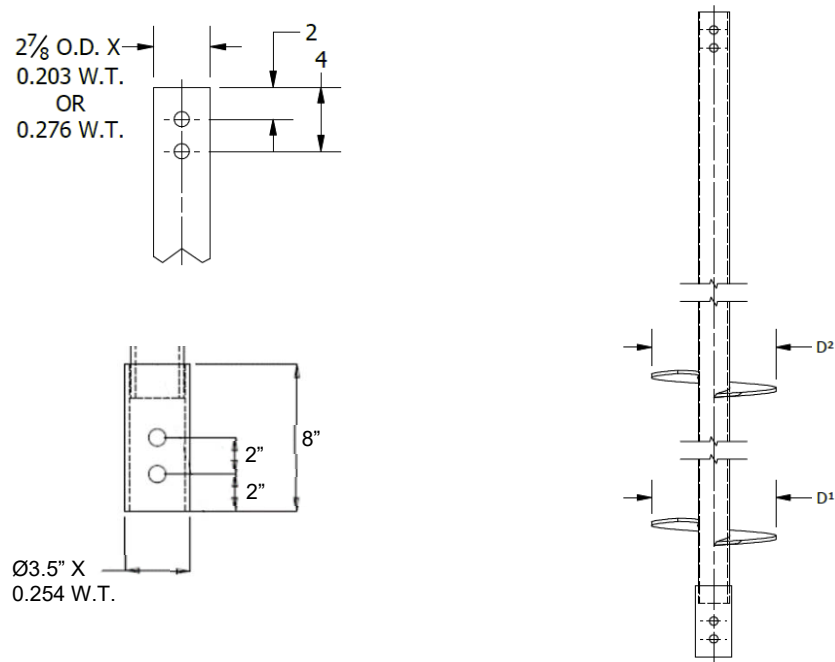

FIGURE 5A—TYPICAL 2 7/8-INCH-DIAMETER FLIGHTED EXTENSION

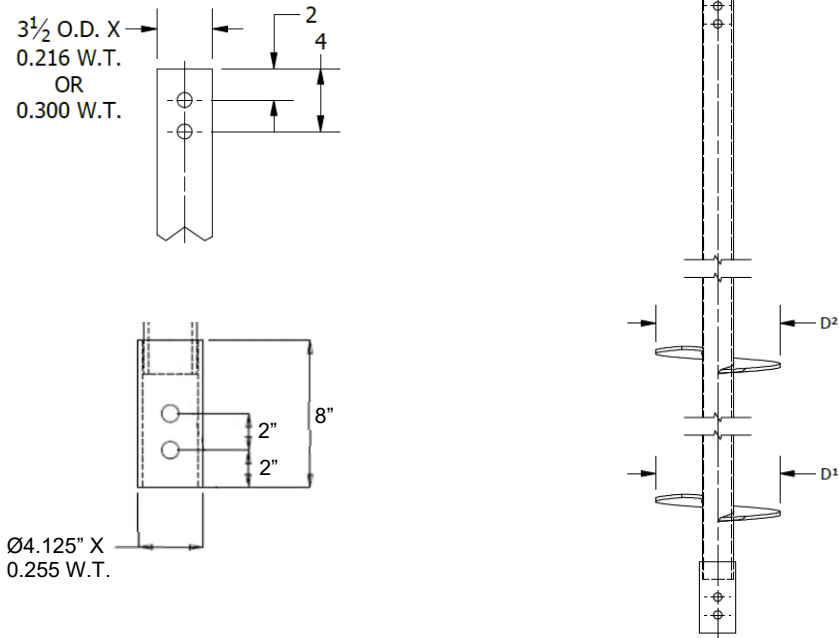

FIGURE 5B—TYPICAL 3 1/2-INCH-DIAMETER FLIGHTED EXTENSION

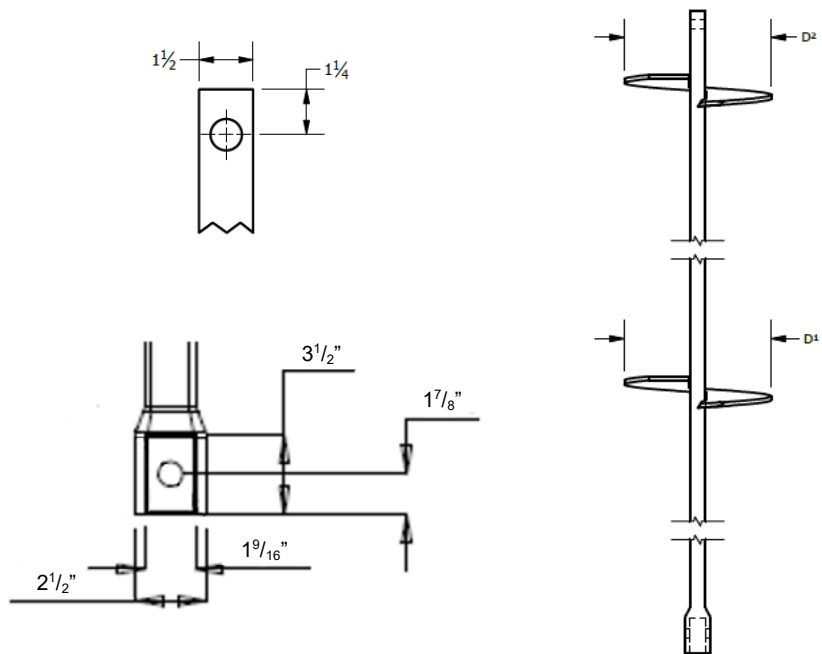

FIGURE 5C—TYPICAL 1 1/2-INCH RCS FLIGHTED EXTENSION

DIVISION: 31 00 00—EARTHWORK
Section: 31 63 00—Bored Piles

REPORT HOLDER:

IDEAL MANUFACTURING, INC.

EVALUATION SUBJECT:

IDEAL HELICAL FOUNDATION SYSTEMS

1.0 REPORT PURPOSE AND SCOPE**Purpose:**

The purpose of this evaluation report supplement is to indicate that the Ideal Helical Foundation Systems, described in ICC-ES evaluation report [ESR-3750](#), have also been evaluated for compliance with the code noted below as adopted by the Los Angeles Department of Building and Safety (LADBS).

Applicable code edition:

- 2020 *City of Los Angeles Building Code* (LABC)

2.0 CONCLUSIONS

The Ideal Helical Foundation Systems, described in Sections 2.0 through 7.0 of the evaluation report [ESR-3750](#), comply with the LABC Section 1810, and are subject to the conditions of use described in this supplement.

3.0 CONDITIONS OF USE

The Ideal Helical Foundation Systems described in this evaluation report supplement must comply with all of the following conditions:

- All applicable sections in the evaluation report [ESR-3750](#).
- The design, installation, conditions of use and identification of the Ideal Helical Foundation Systems are in accordance with the 2018 *International Building Code*® (IBC) provisions noted in the evaluation report [ESR-3750](#).
- The design, installation and inspection are in accordance with additional requirements of LABC Chapters 16 and 17, and Sections 1803 and 1810.3.1.5, as applicable.
- The Ideal Helical Foundation Systems are used to underpin foundations of existing structures or retrofit or remediate deficient foundations of existing structures, and must not be used to support new structures.
- The Ideal Helical Foundation Systems must not be used to resist any horizontal loads.
- The Ideal Helical Foundation Systems that include new construction brackets are not applicable for this supplement.
- Sections 5.2 and 5.15 of the evaluation report [ESR-3750](#) are not applicable to this supplement.

This supplement expires concurrently with the evaluation report, reissued June 2022.

DIVISION: 31 00 00—EARTHWORK
Section: 31 63 00—Bored Piles

REPORT HOLDER:

IDEAL MANUFACTURING, INC.

EVALUATION SUBJECT:

IDEAL HELICAL FOUNDATION SYSTEMS

1.0 REPORT PURPOSE AND SCOPE**Purpose:**

The purpose of this evaluation report supplement is to indicate that Ideal Helical Foundation Systems, described in ICC-ES evaluation report ESR-3750, have also been evaluated for compliance with the code noted below.

Applicable code edition(s):

- 2019 *California Building Code* (CBC)

For evaluation of applicable chapters adopted by the California Office of Statewide Health Planning and Development (OSHPD) AKA: California Department of Health Care Access and Information (HCAI) and the Division of State Architect (DSA), see Sections 2.1.1 and 2.1.2 below.

2.0 CONCLUSIONS**2.1 CBC:**

The Ideal Helical Foundation Systems, described in Sections 2.0 through 7.0 of the evaluation report ESR-3750, comply with CBC Chapter 18, provided the design and installation are in accordance with the 2018 *International Building Code*® (IBC) provisions noted in the evaluation report and the additional requirements of CBC Chapters 16, 17 and 18, as applicable.

2.1.1 OSHPD: The applicable OSHPD Sections and Chapters of the CBC are beyond the scope of this supplement.

2.1.2 DSA: The applicable DSA Sections and Chapters of the CBC are beyond the scope of this supplement.

This supplement expires concurrently with the evaluation report, reissued June 2022.